

## 2 Lamp T5, T5HO, T8, or CFTT5

### APPLICATION

- Subtle enclosure curves provide architectural styling to complement any space.
- Smooth brightness across the face of the luminaire prevents glare and provides excellent visual comfort.
- Directs a controlled amount of light to higher angles to eliminate "cave effect" without creating glare.
- Ideal for modern offices, schools and retail environments.
- Excellent optical efficiency and luminaire efficacy provide significant energy savings.
- Many ballast/lamp systems are available, providing flexibility to tailor the luminaire to specific applications.
- Step dimming ballasts can be switched to less than 50% input power for energy savings to meet most energy codes while maintaining symmetrical illumination.
- Grid, Flange or Z-spline/ Modular models available.

### CONSTRUCTION/FINISH

- One piece die-formed embossed steel housing provides added rigidity, resists damage during shipment/handling.
- Wireway cover is easily removable without tools for quick ballast or wiring access from below.
- T-bar grid clips are built into luminaire ends for quick and easy installation, no extra parts required.

- Suitable for end-to-end mounting.
- End K.O.s for thru wiring or conduit entry in shallow plenums.

### ELECTRICAL

- UL listed for damp locations. Canadian certified optional.
- Emergency ballasts can be incorporated, UL listed for dry locations.
- Systems are available offering electrical system efficacy ratings up to 90 Lumens/Watt.
- Total luminaire efficacy as high as 76 LPW.

### ENCLOSURES

- Center section is flush with outer panels, eliminating the dirt and debris collection typical of suspended "baskets."
- One-piece enclosure hinges down as an assembly for easy access to lamps and ballast from below without tools.
- T-hinges provide secure retention of enclosure and eliminate non-captive parts to hold during servicing.
- Guide-post spring loaded latches allow easy opening and closing of the enclosure.
- Choice of center sections includes diffuse acrylic with smooth or ribbed surface, round perforated steel with overlay, or white radial louver with overlay.
- Smooth side diffusers standard, ribbed optional.
- Any center section can be used with either side diffuser.

### CATALOG NUMBER

<b>2</b>	<b>ST</b>	<b>2</b>	<b>1/2</b>	
<b>WIDTH</b> 2 - 2'	<b>FAMILY</b> ST - SofTrace	<b>NO. OF LAMPS</b> (not included) 2	<b>CENTER DIFFUSER</b> D - Diffuse (Ribbed) DS - Diffuse (Smooth) PMW - Round Perf. w/white overlay WO - Radial louver w/white overlay	<b>BALLAST CONFIG.</b> 1/2 - One 2-lamp ballast
	<b>CEILING TYPE</b> G - Grid F - Flange Z - Z Spline/Modular	<b>LAMP TYPE/WATTAGE</b> 14 - 14wT5 (22") 17 - 17wT8 (24") 24HO - 24wT5HO (22") CF40 - 40wTT5 (22-1/2") CF50 - 50wTT5 (22-1/2") CF55 - 55wTT5 (22")	<b>VOLTAGE</b> 120 277 UNV - Universal Voltage, 120-277 volt	<b>OPTIONS</b> CM - Canadian Market CC - Custom Color F1 - 3/8" flex, 3 wire 18 gauge F2 - 3/8" flex, 4 wire 18 gauge E1* - DEB-1 emerg. ballast, T8 lamps, 350-450 lumens E7* - DEB-7 emerg. ballast, T8 lamps, 600-700 lumens E5* - DEB-5 emerg. ballast, T8 lamps, 1100-1400 lumens E7LP* - DEB-7LP emerg. ballast T5/T5HO, 430-700 lumens E6* - DEB-6LP emerg. ballast, T5/T5HO lamps, 750-1325 lumens GLR# - Fusing, fast blow (# = number of ballasts) LPT730 - Installed T8 lamps, 70+ CRI, 3000K LPT735 - Installed T8 lamps, 70+ CRI, 3500K LPT741 - Installed T8 lamps, 70+ CRI, 4100K LPT830HL - Installed T8 hi lumen lamps, 80+ CRI, 3000K LPT835HL - Installed T8 hi lumen lamps, 80+ CRI, 3500K LPT841HL - Installed T8 hi lumen lamps, 80+ CRI, 4100K LPT830 - Installed T8/T5/T5HO lamps, 80+ CRI, 3000K LPT835 - Installed T8/T5/T5HO lamps, 80+ CRI, 3500K LPT841 - Installed T8/T5/T5HO lamps, 80+ CRI, 4100K PAF - Housing painted after fabrication RIB - Ribbed side diffusers
		<b>BALLAST TYPE</b> EBD - T5/T5HO/T8/CF electronic dimming ballast EB - T5/T5HO/T8/CF electronic ballast, std. ballast factor EBL - T8 Electronic ballast, low ballast factor EBH - T8 Electronic ballast, hi ballast factor EB10I - T8 Electronic ballast, <10% THD, instant start EB10R - T8 Electronic ballast, <10% THD, rapid start EBSD - T8 Electronic step dimming ballast EB115 - 14wT5 Electronic ballast, 1.15 ballast factor EBSD95 - 14wT5 Electronic step dimming ballast, .95 ballast factor EBSD115 - 14wT5 Electronic step dimming ballast, 1.15 ballast factor EBHE - T8 Electronic ballast, high efficiency, std. ballast factor		

### JOB INFORMATION

0167.2-AR

**PHILIPS**  
**Day-Brite**

## ENERGY DATA

Lamp Type	Ballast Type	Input Power (120/277V)	Electrical System Lumens/Watt	
			Std. Lamps*	Hi-lumen Lamps
14	EB	34W / 34W	84	—
	EBSD95@hi	35W / 35W	77	—
	EBSD95@lo	16W / 16W	62	—
	EBSD115@hi	38W / 37W	84	—
	EBSD115@lo	18W / 19W	57	—
17	EB	34W / 34W	76	86
	high eff. EB	30W / 30W	80	<b>90</b>
	EB10I	33W / 33W	75	85
	EB10R	34W / 34W	74	84
	EBL	30W / 30W	76	86
	EBH	43W / 43W	78	88
	EBSD@hi	30W / 30W	77	87
	EBSD@lo	16W / 16W	50	57
24HO	EB	53W / 52W	77	—
CF40	EB	76W / 73W	79	—
CF50	EB	106W / 106W	85	—
CF55	EB	112W / 109W	79	—

\*T8 values assume 70+CRI lamp. 80+CRI lamps with increased lumen ratings are also available.

## DIMENSIONS

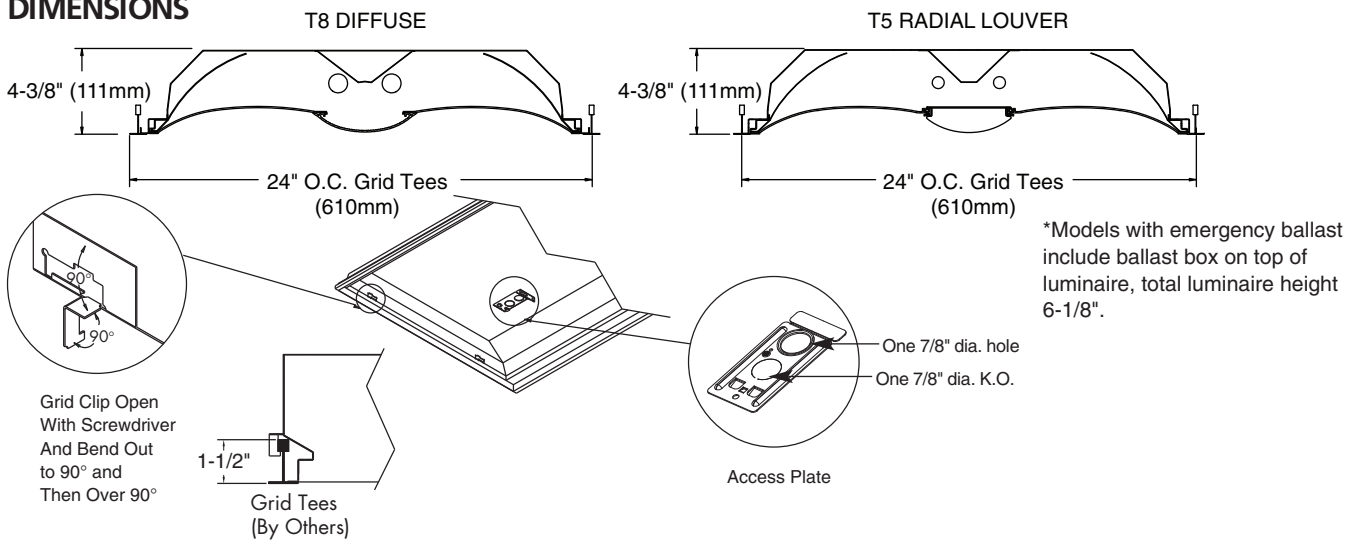

**2** **ST** **G** **2** **17**  
CEILING TYPE

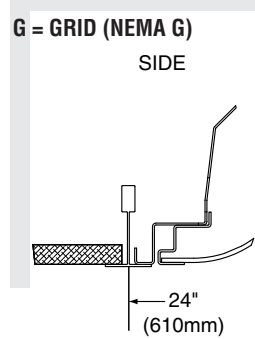

(NEMA Type G)  
Lay-in acoustical ceilings using exposed grid suspension, with tees for fixtures on 24" x 48" spacing.

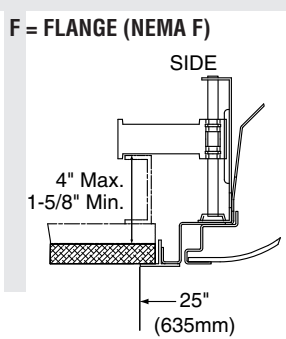

(NEMA Type F)  
Flange for acoustical ceilings using concealed mechanical suspension. Swing-jack mounting brackets: adjustment 4" max. and 1-5/8" min. Refer to sheet 801-CL for cut-out information.

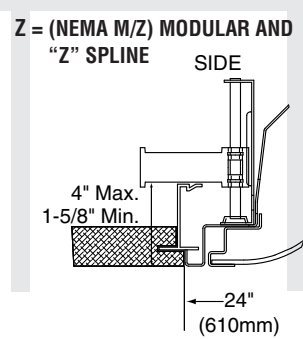

(NEMA M/Z)  
Modular and "Z" Spline using concealed mechanical suspension. Swing-jack mounting brackets: adjustment 4" max. and 1-5/8" min.

**PHOTOMETRIC DATA**

**CATALOG #** 2STG217-D-1/2-EB  
**TEST #**27039 **S/MH=**1.3

**LAMPS =** F1T8  
**BALLAST =** ELECTRONIC

**INPUT WATTS =** 32  
**BALLAST FACTOR =** 0.88

**LER =** 60

COMPARATIVE YEARLY LIGHTING ENERGY COST PER 1000 LUMENS = **\$4.00** BASED ON 3000 HRS. AND \$.08 PER KWH.

**FIXTURE EFFICIENCY=** 81.7%

**T8, DIFFUSE\***  
\*smooth or ribbed center,  
smooth or ribbed sides

CANDLEPOWER				
Angle	End	45	Cross	
0	779	779	779	
5	773	775	777	
10	762	763	765	
15	743	744	745	
20	718	719	721	
25	685	687	693	
30	640	648	659	
35	593	605	629	
40	537	557	595	
45	475	508	559	
50	407	452	516	
55	339	396	461	
60	271	330	391	
65	208	264	317	
70	150	199	240	
75	99	136	166	
80	56	81	89	
85	23	29	30	

MAINTAINED ILLUMINATION TABLE- Square Feet/Fixture*			
<ul style="list-style-type: none"> <li>80-50-20 Reflectances (Ceiling-Wall-Floor)</li> <li>LLF = 0.77 1325 Lumens/Lamp very clean</li> <li>Room width divided by room height = 5 or more, 2 or 1</li> </ul>			
Fixture Size & # of Lamps	Room Width Room Height =	Approx. Area (sq. ft.) per Fixture	
		30 ft-c	50 ft-c
2x2	5	58	35
2-Lamp T8	2	39	-
Diffuse	1	-	-

\*Observe Fixture S/MH Requirements for Specific Applications

COEFFICIENT OF UTILIZATION						
pfc pcc pw RCR	20		70		50	
	70	50 30	70	50 30	50	30
0	96	96 96	94	94 94	91	91
1	89	84 81	86	82 80	80	77
2	81	73 68	79	72 68	69	66
3	73	65 58	71	64 57	60	56
4	68	57 51	66	56 50	55	48
5	61	52 44	59	51 44	48	42
6	56	46 39	56	46 39	44	38
7	53	41 34	52	40 34	40	34
8	48	38 30	47	38 30	36	30
9	46	34 28	45	34 28	34	28
10	42	33 26	41	32 26	30	26

LIGHT DISTRIBUTION			
DEGREES	LUMENS	% LAMP	% FIXTURE
0-30	600	22.6	27.7
0-40	980	37.0	45.3
0-60	1729	65.2	79.8
0-90	2165	81.7	100.0

.77LLF = .94LDD x .93LLD x 0.88BF

**PHOTOMETRIC DATA**

**CATALOG #** 2STG214-D-1/2-EB  
**TEST #**27067 **S/MH=**1.2

**LAMPS =** F14T5  
**BALLAST =** ELECTRONIC

**INPUT WATTS =** 33  
**BALLAST FACTOR =** 1.00

**LER =** 65

COMPARATIVE YEARLY LIGHTING ENERGY COST PER 1000 LUMENS = **\$3.69** BASED ON 3000 HRS. AND \$.08 PER KWH.

**FIXTURE EFFICIENCY=** 88.9%

**T5, DIFFUSE\***  
\*smooth or ribbed center,  
smooth or ribbed sides

CANDLEPOWER				
Angle	End	45	Cross	
0	772	772	772	
5	764	767	772	
10	753	755	760	
15	734	737	739	
20	708	710	712	
25	673	675	679	
30	632	635	640	
35	580	588	605	
40	528	540	574	
45	465	488	543	
50	397	439	507	
55	331	385	460	
60	266	327	402	
65	202	264	328	
70	146	200	254	
75	96	137	177	
80	56	83	96	
85	22	30	29	

MAINTAINED ILLUMINATION TABLE- Square Feet/Fixture*			
<ul style="list-style-type: none"> <li>80-50-20 Reflectances (Ceiling-Wall-Floor)</li> <li>LLF = 0.89 1200 Lumens/Lamp very clean</li> <li>Room width divided by room height = 5 or more, 2 or 1</li> </ul>			
Fixture Size & # of Lamps	Room Width Room Height =	Approx. Area (sq. ft.) per Fixture	
		30 ft-c	50 ft-c
2x2	5	66	39
2-Lamp T5	2	45	-
Diffuse	1	33	-

\*Observe Fixture S/MH Requirements for Specific Applications

COEFFICIENT OF UTILIZATION						
pfc pcc pw RCR	20		70		50	
	70	50 30	70	50 30	50	30
0	106	106 106	103	103 103	98	98
1	96	93 89	93	91 86	86	83
2	88	81 75	85	79 72	76	70
3	80	70 64	78	68 63	67	60
4	72	63 55	70	61 54	58	53
5	68	56 47	66	55 47	53	46
6	61	50 42	60	50 41	47	40
7	57	46 38	56	45 38	44	36
8	54	41 34	52	40 34	40	33
9	50	38 30	48	38 30	36	29
10	46	34 28	46	34 28	34	28

LIGHT DISTRIBUTION			
DEGREES	LUMENS	% LAMP	% FIXTURE
0-30	592	24.7	27.8
0-40	962	40.1	45.1
0-60	1694	70.6	79.4
0-90	2134	88.9	100.0

.89LLF = .94LDD x .94LLD x 1.00BF

**PHOTOMETRIC DATA**

**CATALOG #** 2STG217-PMW-1/2-EB  
**TEST #**27112 **S/MH=**1.4

**LAMPS =** F1T8  
**BALLAST =** ELECTRONIC

**INPUT WATTS =** 31  
**BALLAST FACTOR =** 0.88

**LER =** 52

COMPARATIVE YEARLY LIGHTING ENERGY COST PER 1000 LUMENS = **\$4.62** BASED ON 3000 HRS. AND \$.08 PER KWH.

**FIXTURE EFFICIENCY=** 68.9%

**T8, PERF.**

CANDLEPOWER				
Angle	End	45	Cross	
0	623	623	623	
5	618	623	620	
10	608	610	614	
15	592	597	604	
20	570	580	592	
25	543	558	580	
30	509	533	566	
35	470	505	550	
40	425	472	530	
45	377	435	502	
50	323	393	465	
55	269	344	419	
60	213	289	366	
65	162	231	308	
70	117	180	239	
75	77	123	155	
80	44	66	73	
85	16	16	19	

MAINTAINED ILLUMINATION TABLE- Square Feet/Fixture*			
<ul style="list-style-type: none"> <li>80-50-20 Reflectances (Ceiling-Wall-Floor)</li> <li>LLF = 0.77 1325 Lumens/Lamp very clean</li> <li>Room width divided by room height = 5 or more, 2 or 1</li> </ul>			
Fixture Size & # of Lamps	Room Width Room Height =	Approx. Area (sq. ft.) per Fixture	
		30 ft-c	50 ft-c
2x2	5	49	-
2-Lamp T8	2	33	-
Perf.	1	-	-

\*Observe Fixture S/MH Requirements for Specific Applications

COEFFICIENT OF UTILIZATION						
pfc pcc pw RCR	20		70		50	
	70	50 30	70	50 30	50	30
0	81	81 81	80	80 80	77	77
1	75	71 68	72	69 68	67	65
2	68	61 57	66	60 56	58	55
3	61	55 48	59	54 47	52	46
4	56	47 41	55	46 41	46	40
5	52	42 36	51	41 35	40	35
6	47	39 33	46	38 32	36	32
7	45	34 28	42	34 28	33	28
8	40	32 26	40	32 26	30	25
9	39	28 23	38	28 23	28	23
10	35	27 22	34	27 20	26	20

LIGHT DISTRIBUTION			
DEGREES	LUMENS	% LAMP	% FIXTURE
0-30	485	18.3	26.6
0-40	803	30.3	43.9
0-60	1445	54.5	79.1
0-90	1827	68.9	100.0

.77LLF = .94LDD x .93LLD x 0.88BF

## PHOTOMETRIC DATA

CATALOG # 2STG214-PMW-1/2-EB  
TEST #27115 S/MH=1.4

LAMPS = F14T5  
BALLAST = ELECTRONIC

INPUT WATTS = 34  
BALLAST FACTOR = 1.00

LER = 56

COMPARATIVE YEARLY LIGHTING ENERGY COST PER 1000 LUMENS = \$4.29 BASED ON 3000 HRS. AND \$.08 PER KWH.

FIXTURE EFFICIENCY = 78.9%

T5, PERF.

CANDLEPOWER			
Angle	End	45	Cross
0	639	639	639
5	636	636	636
10	624	625	628
15	608	612	617
20	585	593	603
25	557	572	589
30	523	543	574
35	485	515	561
40	438	482	544
45	386	446	520
50	333	406	489
55	276	359	443
60	220	305	387
65	167	243	337
70	121	185	269
75	81	138	167
80	45	68	81
85	17	17	21

MAINTAINED ILLUMINATION TABLE- Square Feet/Fixture*			
<ul style="list-style-type: none"> <li>80-50-20 Reflectances (Ceiling-Wall-Floor)</li> <li>LLF = 0.89 1200 Lumens/Lamp very clean</li> <li>Room width divided by room height = 5 or more, 2 or 1</li> </ul>			
Fixture Size & # of Lamps	Room Width Room Height =	Approx. Area (sq. ft.) per Fixture	
		30 ft-c	50 ft-c
2x2	5	58	35
2-Lamp T5	2	39	-
Perf.	1	-	-

\*Observe Fixture S/MH Requirements for Specific Applications

.89LLF = .94LDD x .94LLD x 1.00BF

COEFFICIENT OF UTILIZATION						
pfc pcc pw RCR	20		70		50	
	70	50	30	70	50	30
0	93	93	93	92	92	88
1	85	81	79	83	80	77
2	78	70	66	76	69	67
3	70	61	56	68	60	58
4	65	55	47	63	54	47
5	58	48	41	57	47	40
6	55	44	36	53	42	36
7	51	40	33	48	39	33
8	46	35	29	46	35	28
9	44	33	27	42	33	27
10	40	30	23	40	29	23

LIGHT DISTRIBUTION			
DEGREES	LUMENS	% LAMP	% FIXTURE
0-30	497	20.7	26.2
0-40	821	34.2	43.4
0-60	1488	62.0	78.5
0-90	1894	78.9	100.0